

1.	2
1.1	2
1.2	2
1.3	3
2.	4
2.1	4
2.2	4
3.	25
4.	26
4.1	26
4.2	28
4.3	31
4.4	31
4.5	32
5.	33

1

2

1

2

3

4

1

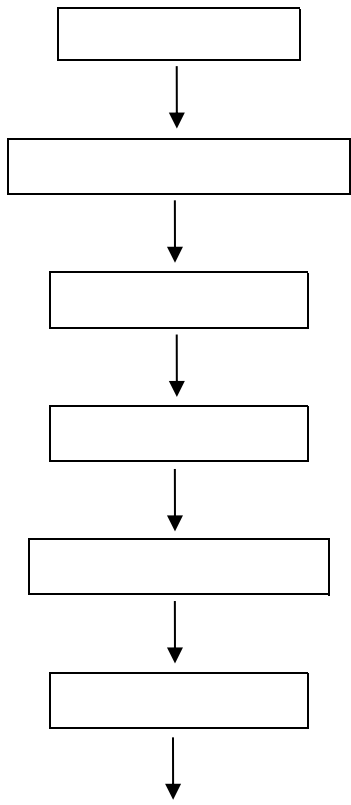

1

1

1

1

1

- 1
- 2
- 3
- 4
- 5
- 6

1958

1984

1994

1998

2000

2003

2011

2017

2

2

1		/	10000	
2		/	1000	
3		/	14000	
		/	1000	
		/	5000	
		/	3000	
		/	2500	
		/	1500	
4		/	300	
5		/	4000	40 /
6		/	1000	25 /
7		/	1000	
8		/	2000	200
9		/	5000	200
10		/	500	25
11		/	500	25
12	31	/	19325	

3

			/	
1			5000	
2		30	150	
3		30	260	
4		40	2040	
5			1760	
6			2725	
7			275	
8			412	
9		98	200	
10		50	451	
11			210	
12			250	
13		30	145	
14			570	
15			612	
16			122	
17			180	
18			1102	
19			735	
20			1543	
21			6061	
22			2609	
23			441	
24			367	
25			1740	
26			93	
27			3600	
28			740	
29			2130	
30			70	
31			12	
32			2320	
33			500	
34			950	
35		A	780	
36			840	
37			480	
38			520	
39		50	320	
40		35	120	
41		5	120	
42			130	
43		10	240	
44			102	
45			210	

46			150	
47			138	
48			3.0	
49			150	
50			30	
51			27	
52			18	
53			3	
54			300	
56			480	
57			545.56	
58			1204.36	
59			3.40	
60			2849.12	
61			1591.4	/
62			1019.68	
63			600.16	
64			4.32	
65			4078.44	
66			368.28	
67			1277.02	
68			1187.74	/
69			29.25	
70			712.89	
71			769.58	
72			424.63	
73			501.16	
74			10	
75			10.68	
76			1332.63	
77			28	
78			2400	/
79			1700	
80			2700	
81			8	
82			4345.7	/
83			1934.3	
84			2147.7	
85			1480.7	
86			220.3	/
87		A	453.4	
88			5	
89			363.3	
90			5	
91			175.8	/
92		9-	293.8	
93		-	173.7	
94			40.0	
95			167.5	

96			195.8	
97			50.0	

1

2-1

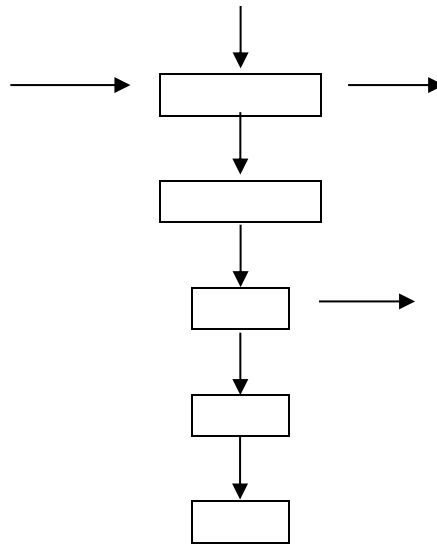

2-1

2

2-2

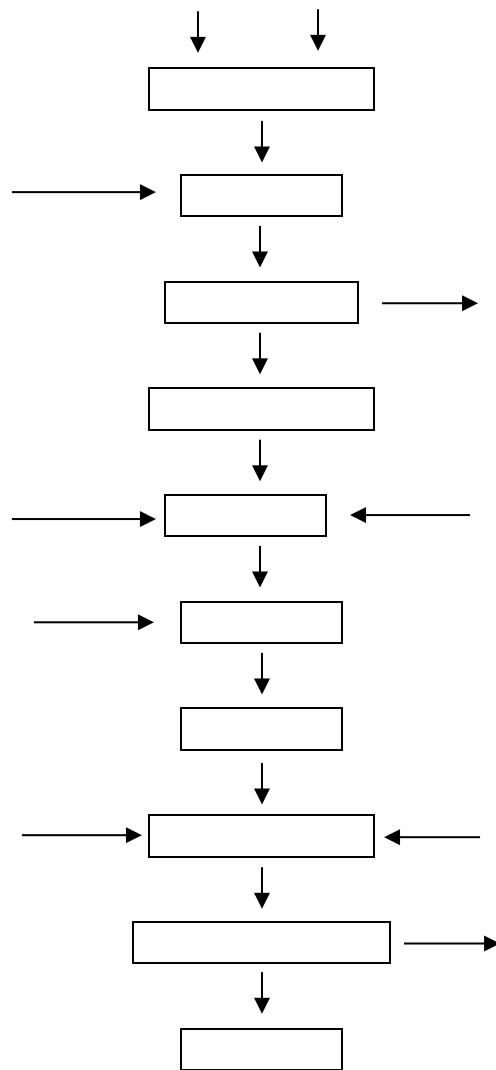

3.5

2-2

3

2-3

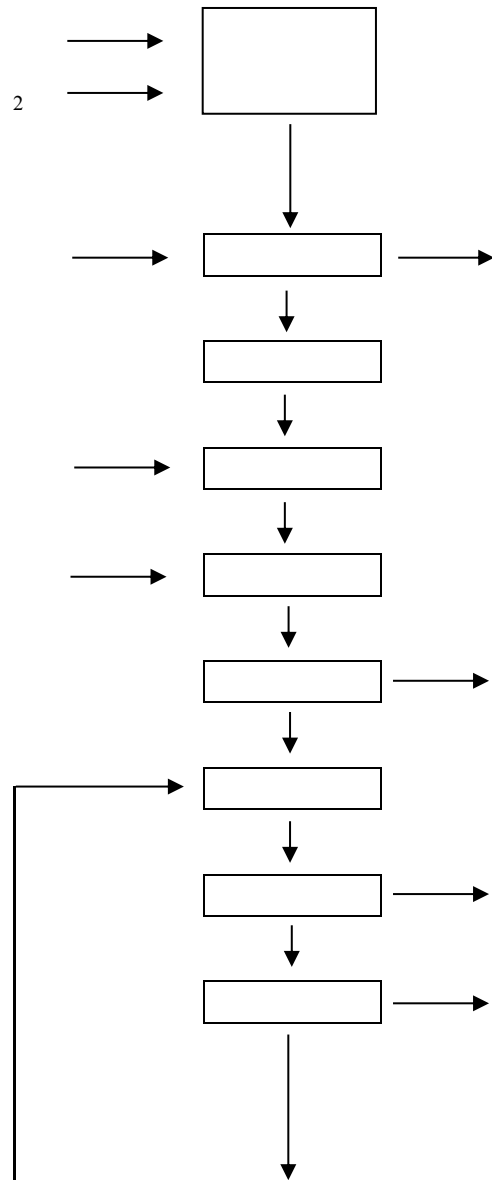

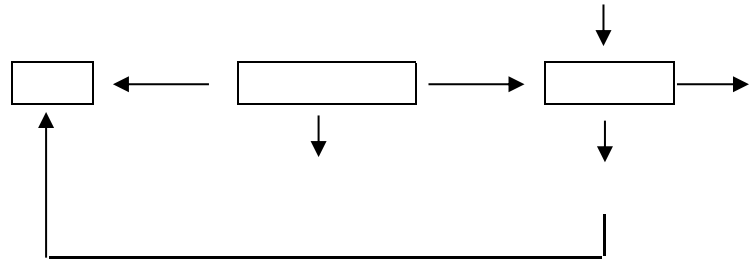

4

2-4

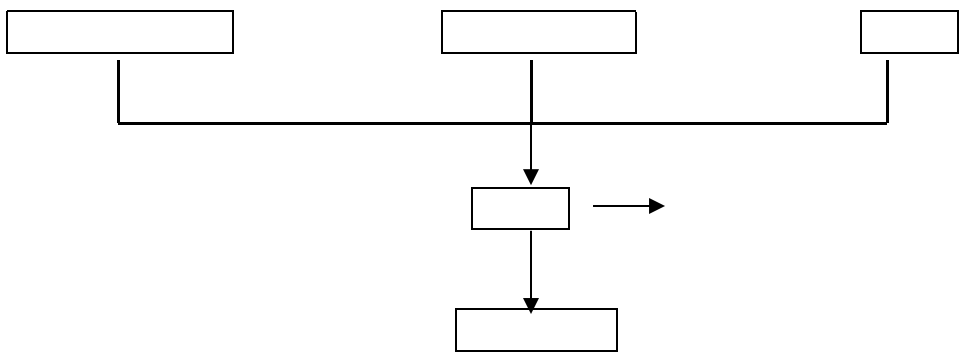

5

2-5

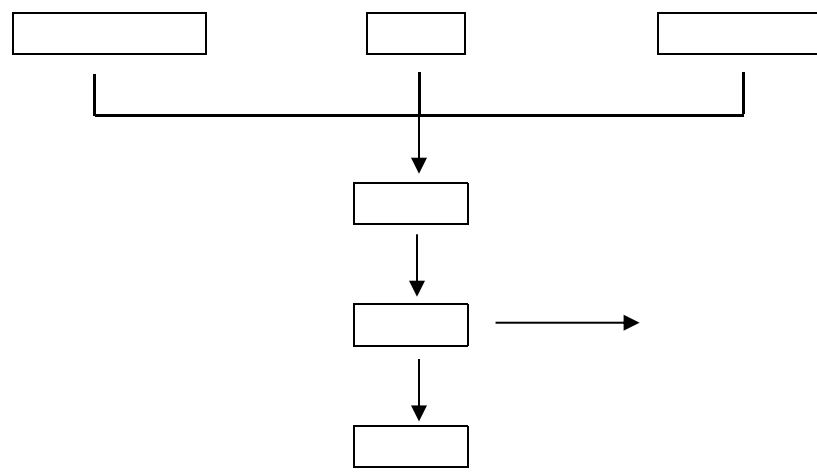

6

2-6

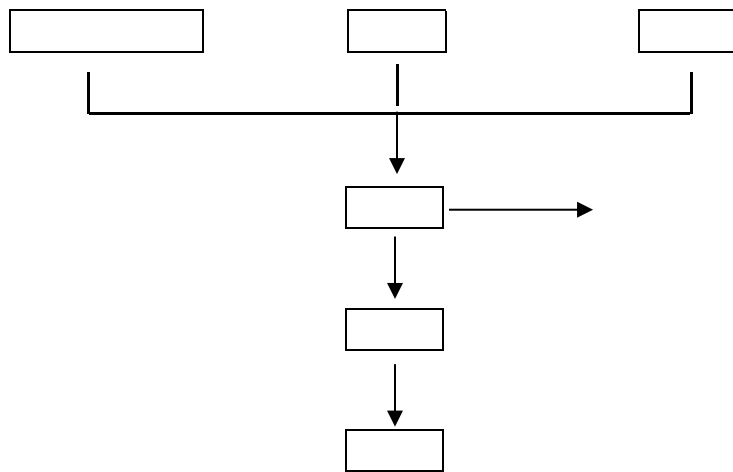

2-6

7

2-7

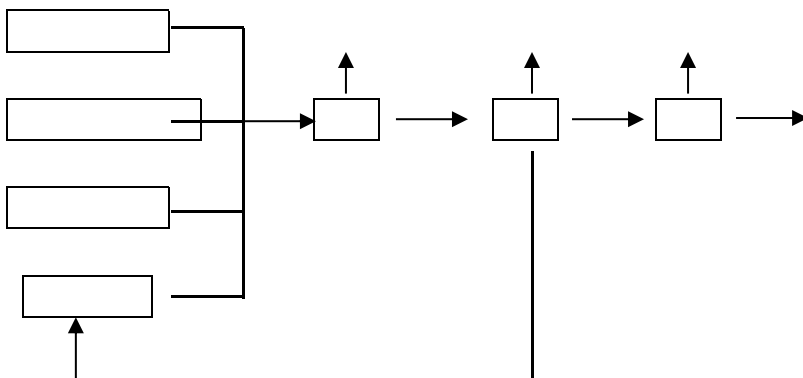

8

2-8

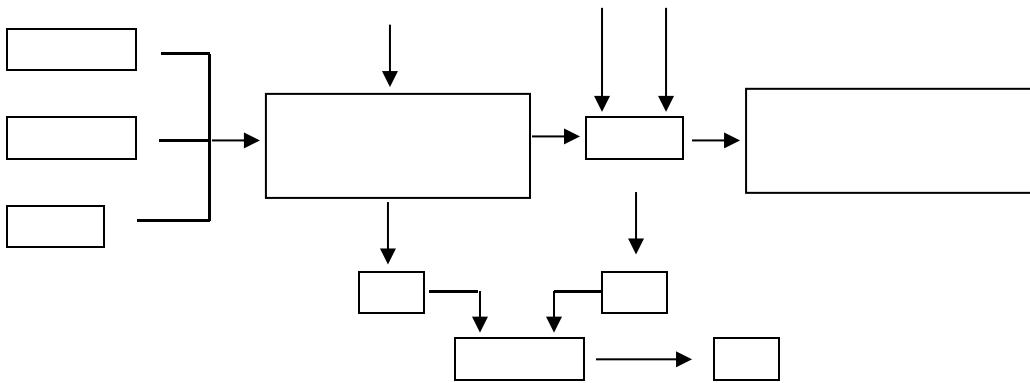

9

2-9

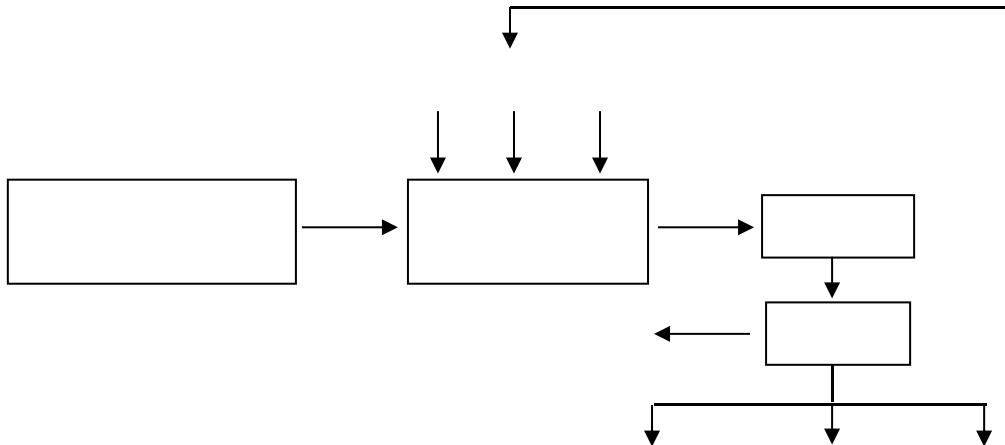

↓
AA

2-12 AA

3

2-13

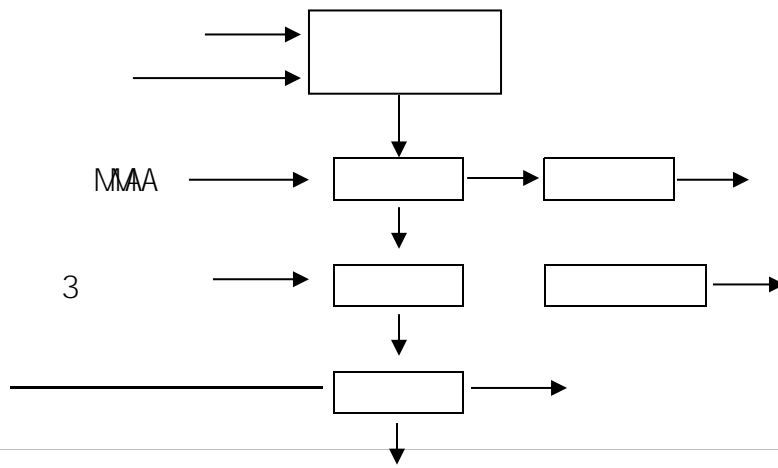

2-13

4

2-14

4-2

+

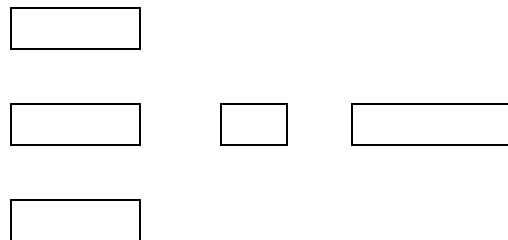

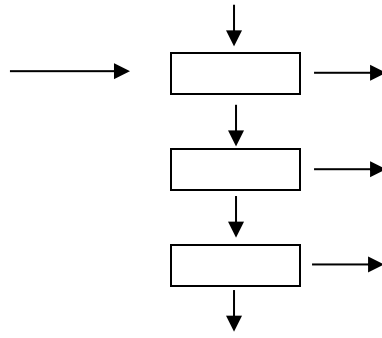

2-14

12

1

2-16

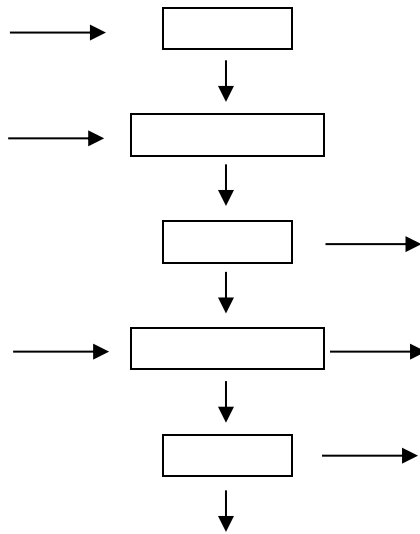

4-1

2

2-17

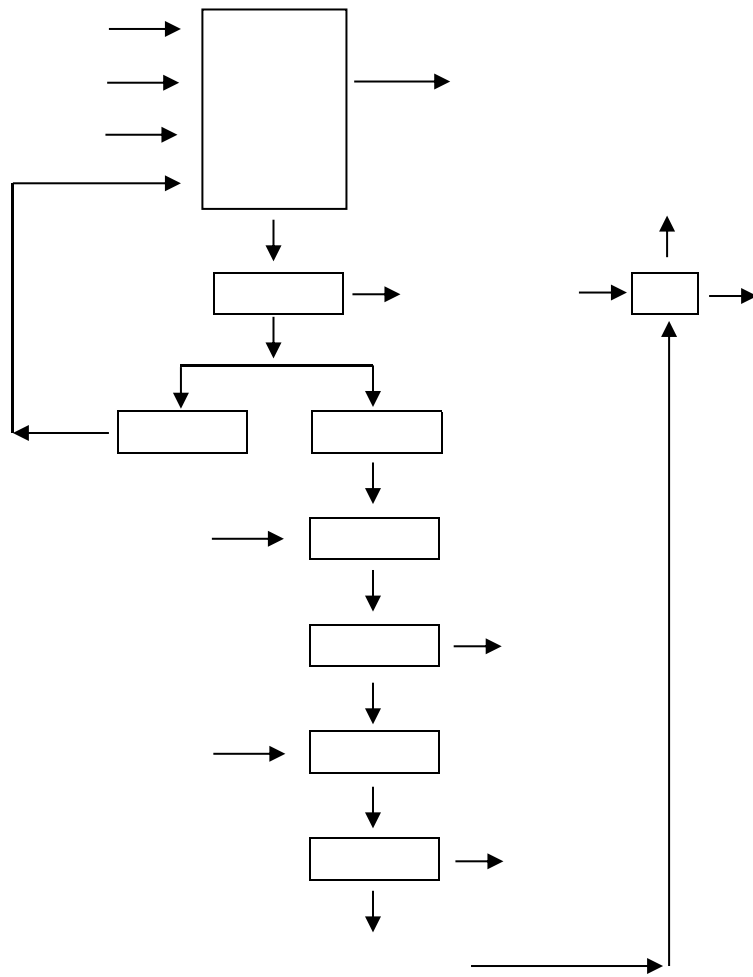

2-17

3

2-18

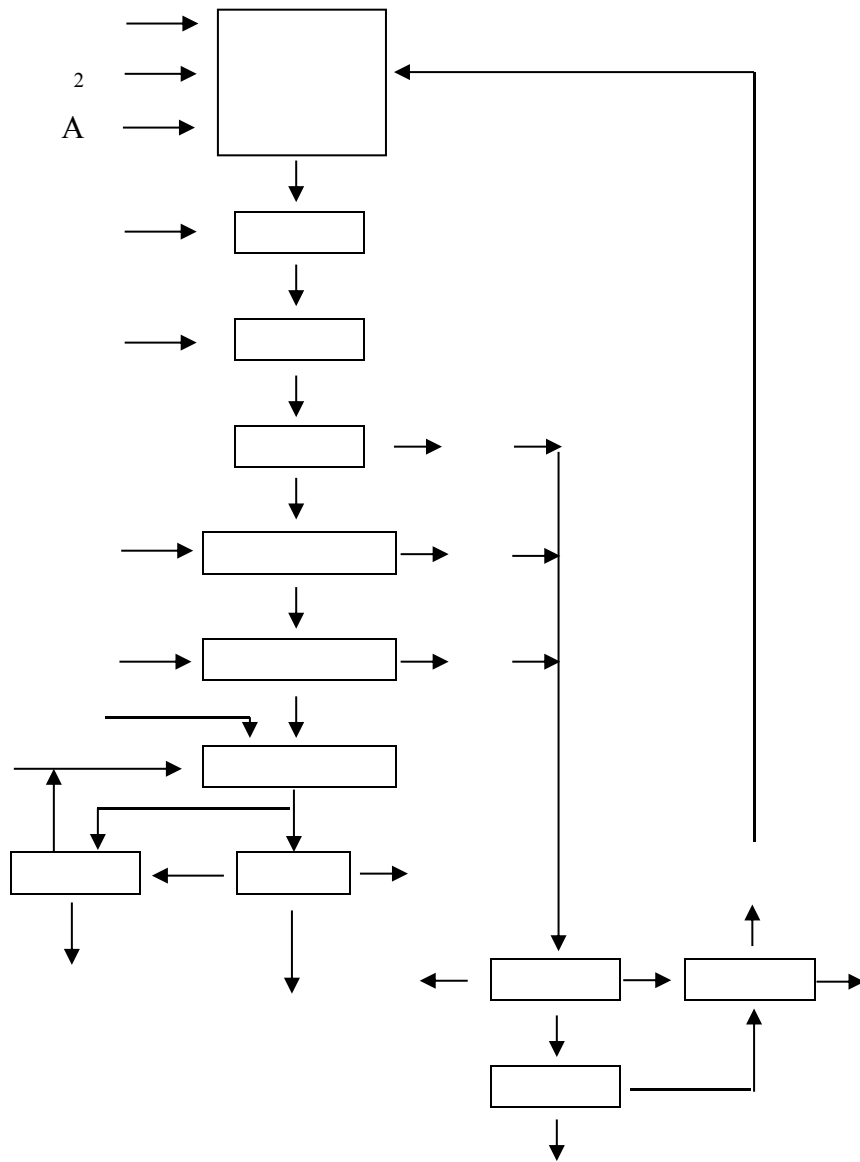

2-18

13

2, 3-

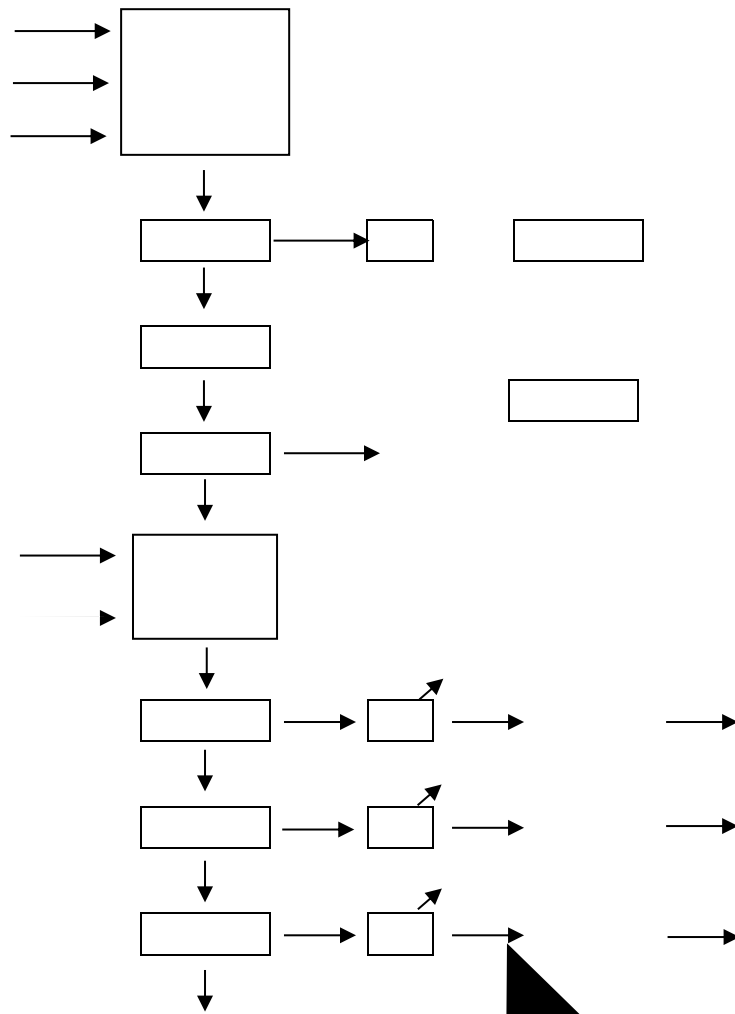

2-19

2-19

14

2-20

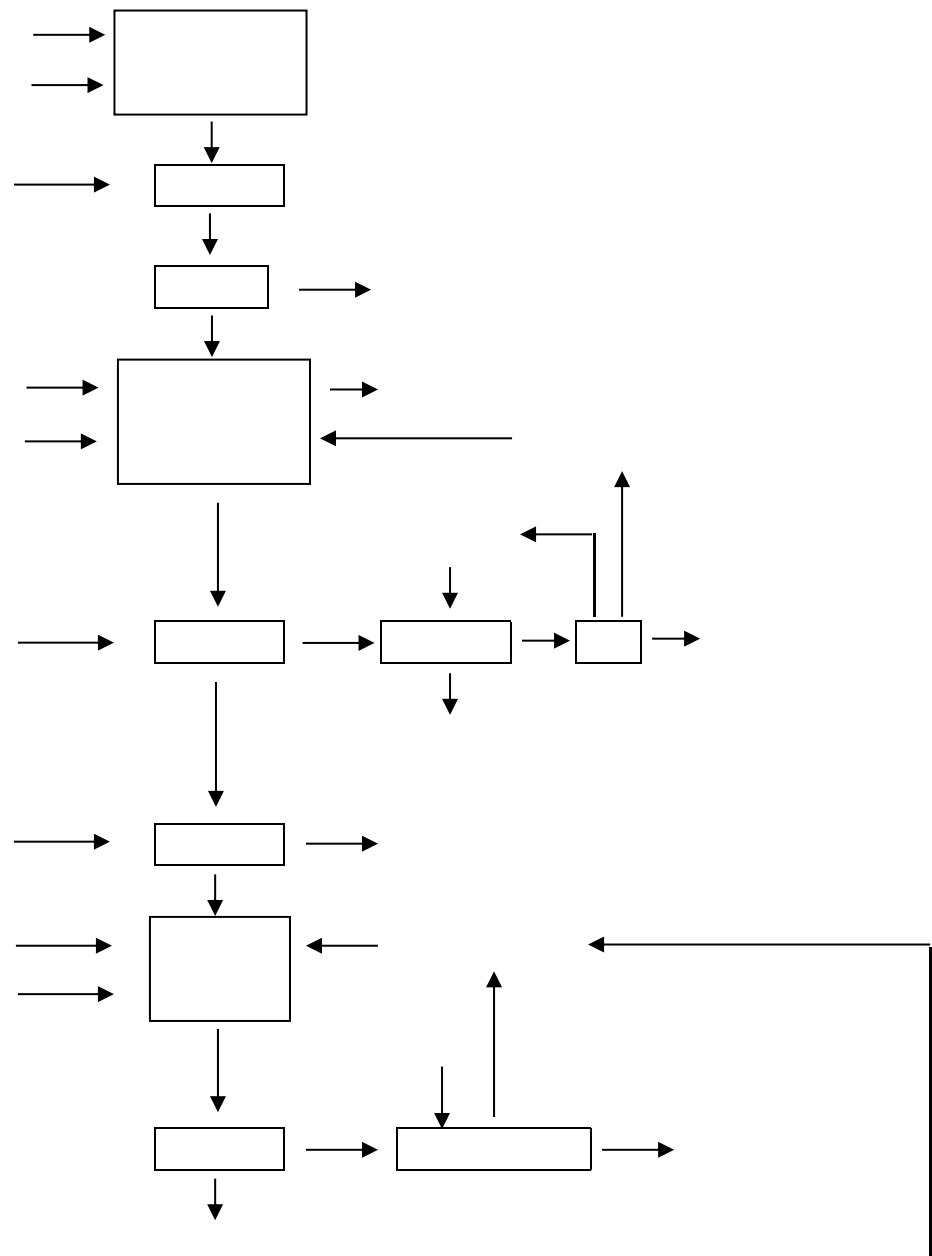

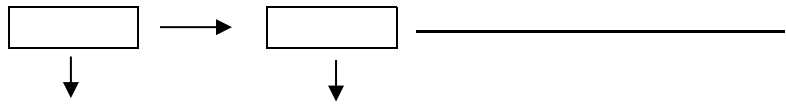

2-20

15

2-21

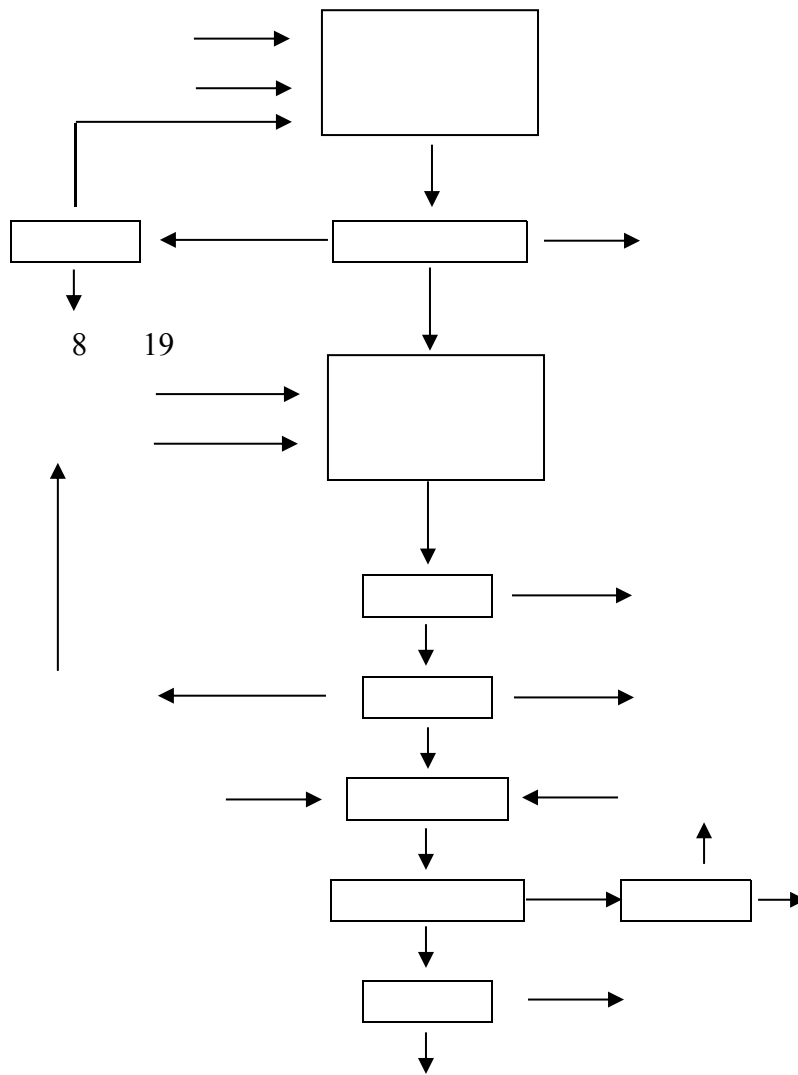

2-21

16

2-22

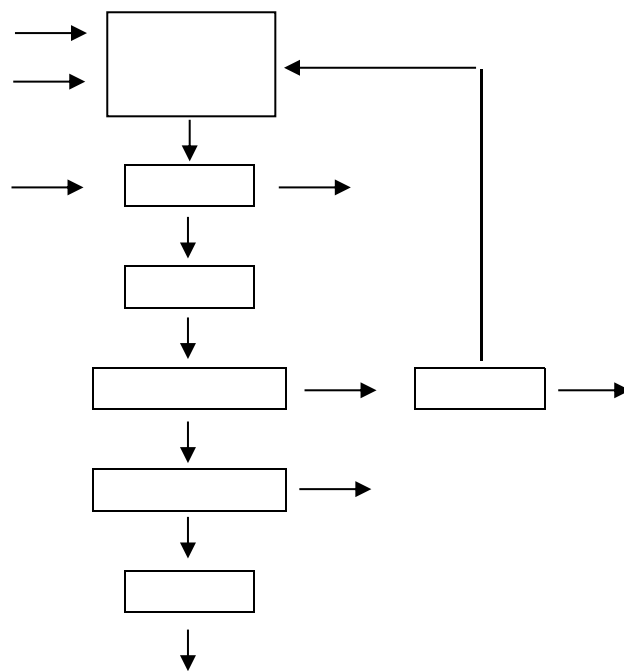

2-22

1

2

1200²

1

2

1

6

4

4

	1A
	1B
	1
	1
	1
	1

5

	3	1A01		
		1A02		
		1A03		
	2	1B01		
		1B02		
	2	1 01		
		1 02		
	2	1 01		
		1 02		
	2	1 01		
		1 02		
	1	1 01		
	1	1 01		
	1	1 01		

0.2 1.5

0.5

0.5 /

29.5

3-5

36.00

5

80-100 /

6

7

	3	1A01	111° 43'48"	28° 57'9.36"	
		1A02	111° 44'11.83"	28° 57'6.84"	
		1A03	111° 44'19.104"	28° 57'6.444"	
	2	1B01	111° 44'28.67"	28° 57'8.316"	
		1B02	111° 44'27.13"	28° 57'4.428"	
	2	1 01	111° 44'24.214"	28° 57'10.764"	
		1 02	111° 44'27.6"	28° 57'10.08"	
	2	1 01	111° 44'28.67"	28° 57'10.36"	
		1 02	111° 44'33.792"	28° 57'4.68"	
	2	1 01	111° 44'33.792"	28° 57'10.764"	
		1 02	111° 44'33.792"	28° 57'10.872"	
	1	1 01	111° 43'36.62"	28° 57'5.832"	
	1	1 01	111 44'27.61"	28 53'25.2"	
	1	1 01	111° 44'34.872"	28° 57'15.22"	

	2	2A01	111° 43'48"	28° 57'9.36"	
		2A02	111 44'19.104"	28 57'6.444"	
	1	2B01	111 44'28.67"	28 57'8.316"	
	1	2 01	111 44'28.67"	28 57'10.36"	
	1	2 01	111 43'36.62"	28 57'5.8.32"	
	1	2 01	111 43'40.6"	28 57'15.01"	
	1	2 01	111 44'27.61"	28 53'25.2"	

2

2

<2

2

0 -50

50

0.5

2

9

9

	1A01	
	1A02	
	1A03	
	2B01	
	2B02	
	2 01	10 ⁻ 40
	2 02	
	2 01	
	2 02	
	2 01	
	2 02	
	2 01	
	1 01	10 ⁻ 40
	1 01	10 ⁻ 40

B14848-93

10

10

"

"

1

	1A			
	1B			
	1			
	1			
	2A			
	2B			
			/	
	1A			
	1B			
			/	
	2A			
	2B			